

MARK	EQUIPMENT LISTING AND SUPPLIER	CSI	CUSTOMER	MARK	EQUIPMENT LISTING AND SUPPLIER	CSI	CUSTOMER
A	FLOWTITE SINGLE WALL FIBERGLASS TANK 600 - 60,000 GALLONS	X		H	FLEXIBLE SUCTION HOSE w/ FLOATING FILTER		X
B	FRP HOLD DOWN STRAP & TURNBUCKLE ASSEMBLY	X		I	PUMP CONTROL FLOAT SWITCH		X
C	PRECAST DEADMAN ANCHORS WITH EYEBOLTS	X		J	SMOOTHING INLET DIVERTER		X
D	ACCESS OPENING COLLAR w/ EXTERNAL ADHESIVE CHANNEL	X		K	ROOF GUTTER COLLECTION SYSTEM		X
E	WATERTIGHT FIBERGLASS ACCESS RISER w/ LOCKABLE LID	X		L	GUTTER DOWNSPOUT COLLECTION FILTER		X
F	PVC PIPE STUB-OUT (OVERFLOW)	X		M	TANK VENT w/ SCREEN		X
G	SUCTION PUMP w/ HOUSING		X	N	OPTIONAL LEVEL INDICATOR FITTING	X	

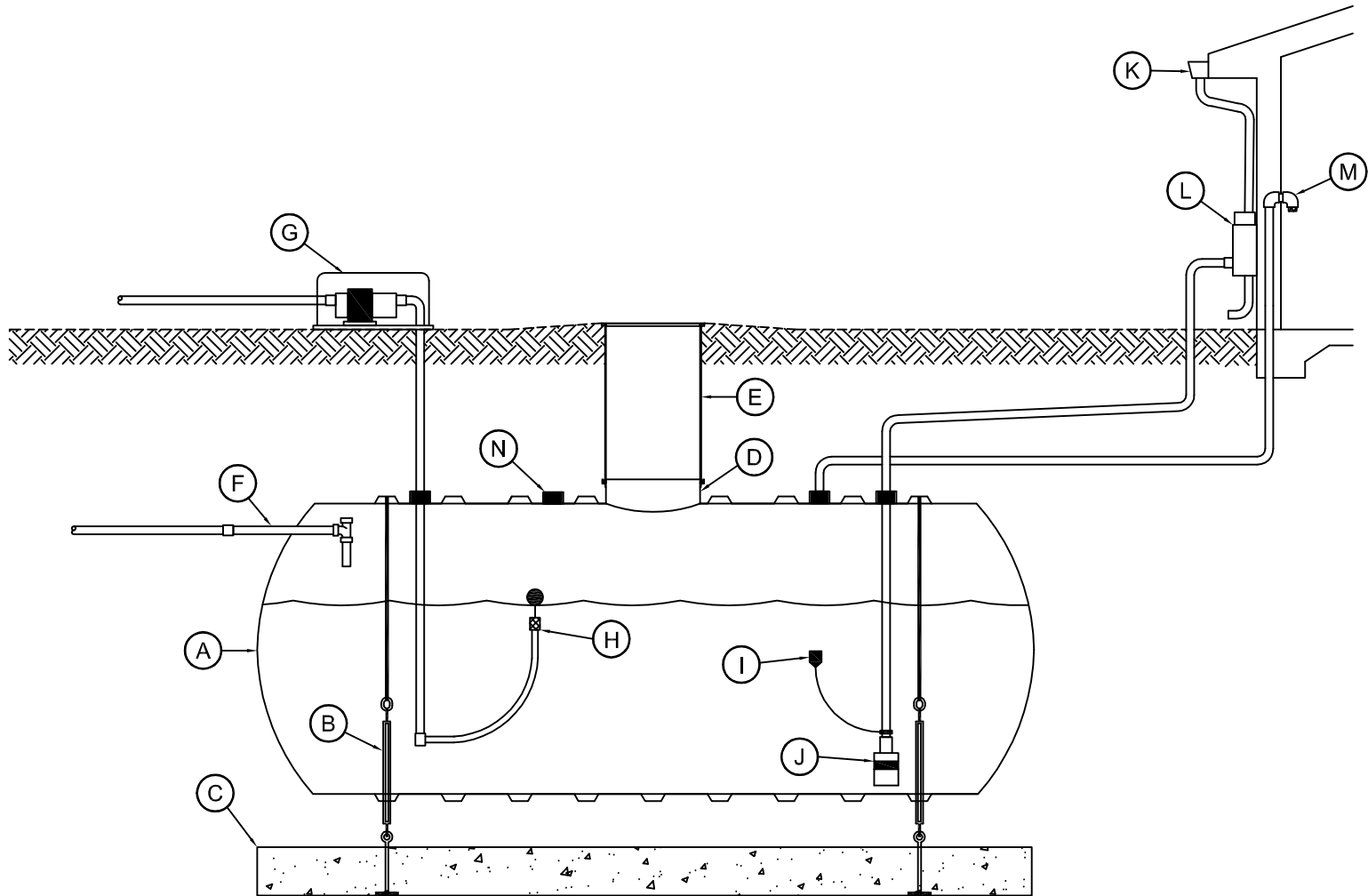

THIS DRAWING IS FOR ILLUSTRATIVE PURPOSES ONLY. IT IS THE RESPONSIBILITY OF THE PURCHASER AND/OR ENGINEER TO DESIGN A SYSTEM IN COMPLIANCE WITH ALL GOVERNING MUNICIPAL CODES.

TYPICAL ILLUSTRATION DRAWING RESIDENTIAL RAINWATER HARVESTING

