

Rainwater Harvesting Aboveground Tank Model RWH (48) 500

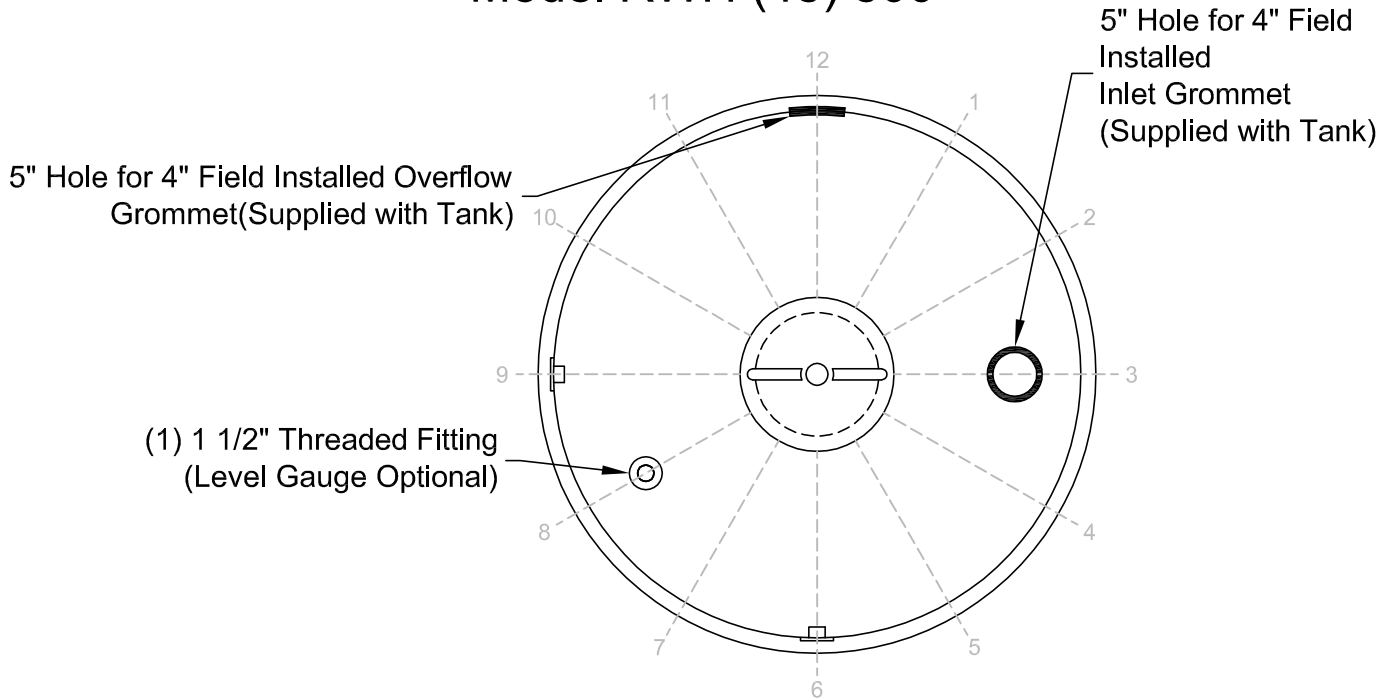

TOP VIEW

14" O.D. Access Lid
(11 1/4" I.D. Opening)

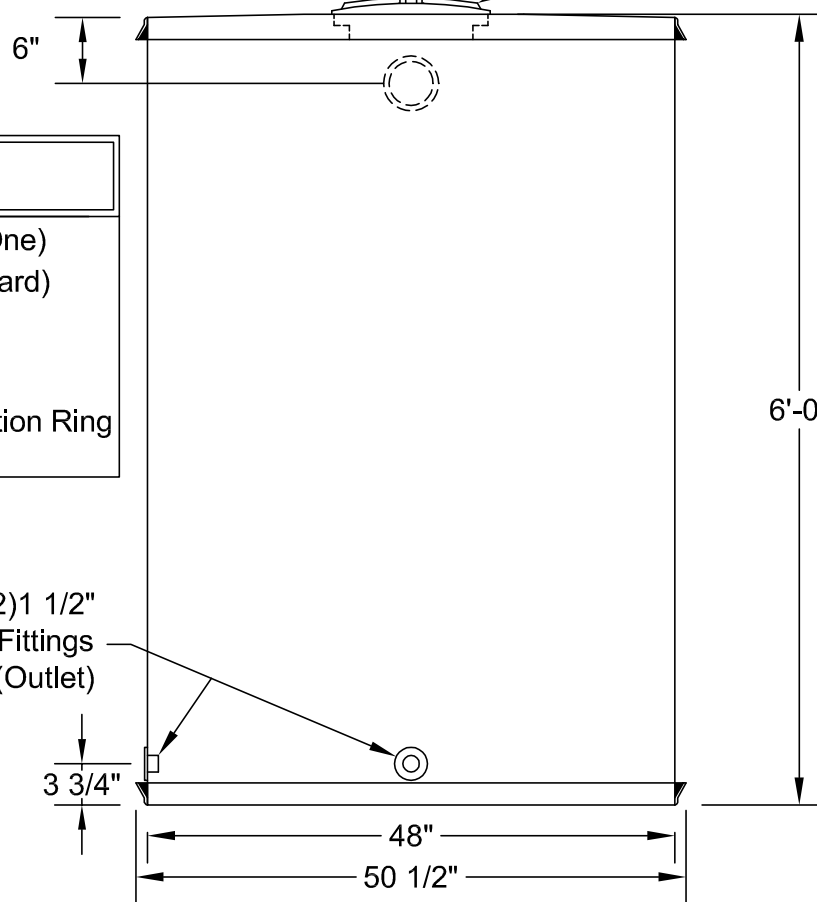

ELEVATION VIEW

- SEE SPEC #PE-C45.03

Available Finishes (Choose One)

 - Natural Fiberglass (Standard)
 - Desert Sand
 - Forest Green
 - 54" dia x 6" Long Foundation Ring (Same Finish as Tank)



CONTAINMENT
SOLUTIONSSM

CUSTOMER			RWH AGT (48) 500 Gallons				DATE: 7/1/2010
APPROVAL SIGNATURE:	SIGNATURE DATE:	NOM. WEIGHT: 190 LBS.	DRAWN BY: J.HARMON	REV #: B	REV DATE: 1/1/2014	REV BY: RSO	DWG NUMBER: RWH AGT(48)-500