

Rainwater Harvesting Aboveground Tank Model RWH (60) 875

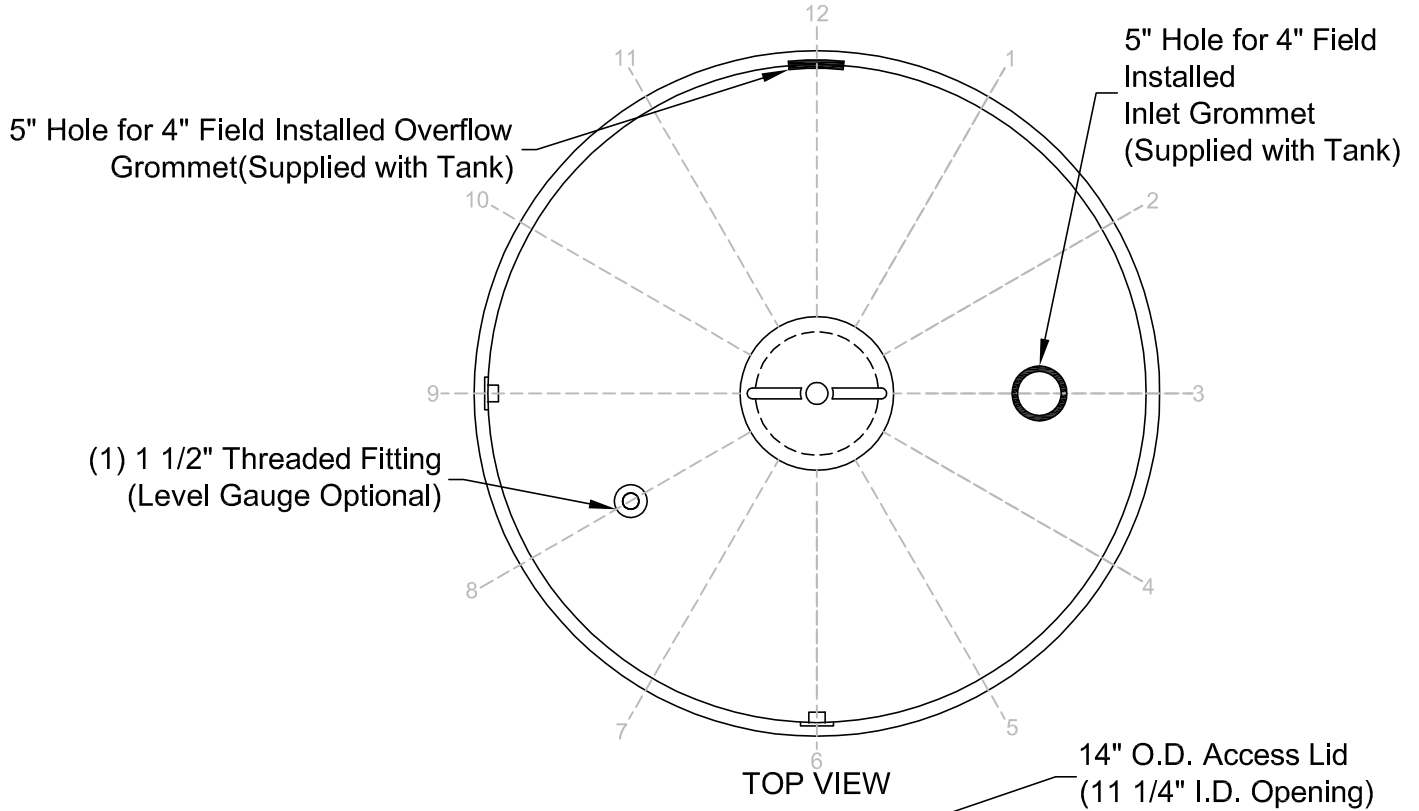

TOP VIEW 14" O.D. Access Lid
(11 1/4" I.D. Opening)

- SEE SPEC #PE-C45.03**

Available Finishes (Choose One)

 - Natural Fiberglass (Standard)
 - Desert Sand
 - Forest Green
 - 66" dia x 6" Long Foundation Ring (Same Finish as Tank)

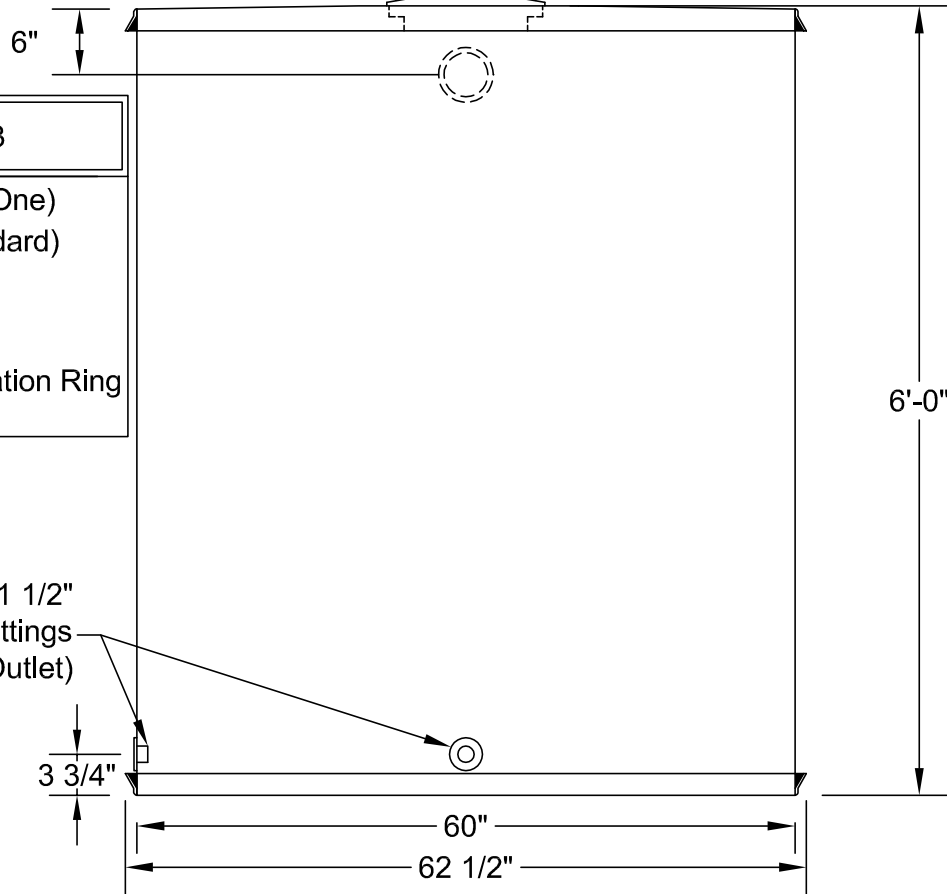

ELEVATION VIEW



CUSTOMER			RWH AGT (60) 875 Gallons				DATE: 7/1/2010
APPROVAL SIGNATURE:	SIGNATURE DATE:	NOM. WEIGHT: 250 LBS.	DRAWN BY: J.HARMON	REV #: B	REV DATE: 1/1/2014	REV BY: RSO	DWG NUMBER: RW H AGT(60)-875