

Single-Wall Tank Sumps Installation Instructions & Operating Guidelines



Fiber Glass Systems | **NOV**

THIS PAGE IS INTENTIONALLY LEFT BLANK.

Important Information - Follow all Instructions

1. Introduction.....	2
2. Handling/Storage.....	3
3. Assembly Instructions.....	3
4. Adhesive & Layout Instructions.....	3
5. Assembled Tank Sumps.....	5
6. Flat Bottom Tank Sumps.....	6
7. Post Assembly Test.....	6
8. Backfill.....	6
9. Surface Slab & Tank Sumps Clearances.....	7
10. Operating Guidelines.....	7
11. Tank Sump Installation Checklist.....	7-8

1. INTRODUCTION

- 1.1. The purpose of this manual is to provide specifiers, owners and contractors with detailed instructions for installing fiberglass reinforced plastic (FRP) single-wall tank sumps (also referred to as turbine enclosures).
 - 1.2. Tank sump installation is a specialized business. If you do not have the proper experience and you have not completed training for tank sump installation in the last 24 months, please contact a trained contractor, or call for a list of trained contractors.
 - 1.3. Proper installation is required to assure the long-term performance of Containment Solutions™ Tank Sumps. These instructions must be followed. Failure to comply will void the limited warranty and may cause tank failure.
 - 1.4. It is the responsibility of the owner, installer and operator to understand and follow all installation requirements.
 - 1.5. For a UL 2447 Listed sump, UL Listed sump fittings of the compression gasketed type or adhesive bonded type shall be used in accordance with the fitting manufacturer's installation instructions.
- 1.6. Safety**
- 1.6.1. These instructions should not be interpreted in any way to put one's health at risk, or to harm property and/or the environment.
 - 1.6.2. Keep this manual available at the installation site and refer to safety procedures as needed.
 - 1.6.3. The following definitions will serve as a guide when reading this manual:

⚠ WARNING

Indicates a potentially hazardous situation, which if not avoided could result in death or serious injury.

⚠ CAUTION

Indicates a potentially hazardous situation, which if not avoided may result in minor or moderate injury.

NOTICE

Indicates a potentially hazardous situation, which if not avoided may result in property damage.

1.7. Important Information

- 1.7.1. Proper installation of each tank sump is essential to ensure the safety of all the individuals involved in the installation; to prevent tank sump damage and/or failure, which could lead to product loss and environmental contamination; to validate the tank sump limited warranty.

1.8. Important Reminders

- 1.8.1. Tank sumps must be installed according to these instructions and NFPA 30, 30A, 31, OSHA and all applicable Federal, State, Local, or Provincial, construction, safety and environmental codes and regulations.
- 1.8.2. Any variances or deviations which are in direct conflict with these published installation instructions must be approved in writing prior to the installation by Tank Technical Support.
- 1.8.3. The presence of any company representative at the job site does not relieve the contractor of responsibility to follow these installation instructions.

1.9. Tank Sump Limited Warranty Activation

- 1.9.1. These instructions must be followed.
- 1.9.2. Installing contractor must be trained in accordance with the contractor training course in effect at the time of the installation.
- 1.9.3. The Installation Checklist must be properly completed and signed by the tank owner's representative and the installing contractor at the time of installation.
- 1.9.4. The tank sump installation checklist, these instructions, and any correspondence related to the tank sump installation must be retained by the tank owner. The checklist will be required and must be provided when making a warranty claim.
- 1.9.5. The tank sump must be continuously monitored for piping leaks using an electronic leak monitoring sensor.
- 1.9.6. The tank sump must be tested after assembly and before backfilling using the procedures described in this manual.
- 1.9.7. Tank sumps must be installed using our assembly kits. Failure to use approved kits will void the tank sump limited warranty.

1.10. Before You Begin

⚠ WARNING

To prevent fire or explosion hazard, it is recommended to use air driven tools whenever possible. Do not use electrical power tools where flammable vapors or liquids exist. Also, when electric hand tools are used, be aware of potential shock hazards. Wear protective clothing and eye protection.

Do not enter tank or tank sumps unless following OSHA guidelines for confined space entry. Failure to follow OSHA guidelines could result in death or serious injury.



ASPHYXIATION



FIRE



EXPLOSION

- 1.10.1. Read, understand and follow these instructions.
- 1.10.2. Barricade the work area.

Field Service Department, Mt. Union, Pennsylvania (800) 822-1997 - (814) 542-8520
 Tank Technical Support, Conroe, Texas (800) 537-4730 - (936) 756-7731

- 1.10.3. Review and prepare to complete the installation checklist as the installation progresses.
- 1.10.4. If you have questions on other tank sump installation details, call Technical Support.

2. HANDLING & STORAGE

⚠ CAUTION

In freezing conditions, protect collar and tank sump from water accumulation. Freezing water may cause damage.

- 2.1. Visually inspect the tank sump components for shipping or handling damage. If damage is found, contact Field Service.
- 2.2. Wear gloves.
- 2.3. Do not roll, drop, or bounce.
- 2.4. Tank sump parts and kits should be stored in upright position.
- 2.5. Set on smooth surface.
- 2.6. The tank sump must be secured to prevent damage from high winds. Proper precautions should be taken to protect adhesive channels.
- 2.7. All assembly kits (Kit AD E or Kit LK) should be stored in a location at 50° - 100°F (10° - 38°C). Use by expiration date shown on the box.
- 2.8. If a sump part is damaged during handling:
 - 2.8.1. If the part can be repaired without affecting the adhesive joint or the ability to install fittings in the sump wall, then the damage may be repaired in the field using a layup kit supplied. White grind the area around the damage extending a minimum of 3" beyond the damage and layup with catalyzed resin and 5 layers of the supplied 1.5 oz/ft² glass mat. After the layup is cured, assemble the sump and test the repaired area for leaks.
 - 2.8.2. If the damage is to an adhesive joint or the fitting installation portion of the sump, the part must be replaced or Field Service contacted to perform a field repair of the damaged part.

3. ASSEMBLY INSTRUCTIONS

⚠ CAUTION

Tank sump must be isolated from direct traffic loading.

- 3.1. Dry fit all tank sump components prior to installation.
 - 3.1.1. Determine any length changes required to insure the minimum required clearance between the tank sump top and concrete.
 - 3.1.2. Confirm enclosure top is level.
 - 3.1.3. Verify fill/vapor spill buckets will properly align with lid opening.
- 3.2. If required, trim tank sump body extension using a carbide tipped blade or a masonry blade. The tank sump body extension is the only component of the tank sump that can be trimmed (see Figure 3-1).
- 3.3. Field cuts must be within ±1/2 in. of square. Gaps between two joints greater than 1/2" may be covered with a maximum 1 in. wide tape.
- 3.4. Remove any foreign matter from adhesive channel.
- 3.5. Using a contractor supplied 40-grit grinding disk, grind all mating surfaces until white in color.
 - 3.5.1. Adhesive Joints - Grind all the surfaces that will contact the adhesive, then wipe free of dust with a clean cloth.
 - 3.5.2. Layup Joints - Grind a minimum of 4 in. onto each part where the layup will be applied, then wipe free of dust with a clean cloth.

- 3.5.3. Ensure mating surfaces are free of contaminants and dry.
- 3.5.4. Do not use oil-based solvents, soap, or water to clean surfaces.
- 3.6. Position tank sump on collar (see Figure 3-1).

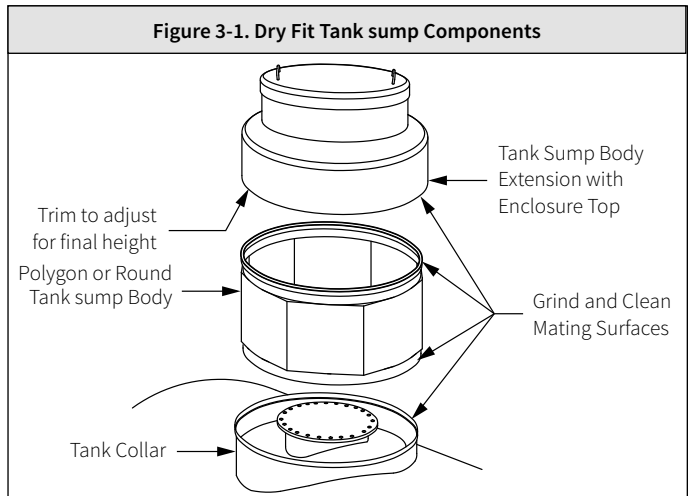

- 3.7. Use a rubber mallet, if necessary to seat tank sump on collar.
- 3.8. Confirm that surfaces and/or adhesive channels are dry and clean before mixing or applying the adhesive.

4. ADHESIVE & LAYUP INSTRUCTIONS

⚠ WARNING

After mixing the adhesive / resin and hardener materials and vapors are flammable. To prevent fire or explosion hazard, if a heat gun (or other ignition source) is used for supplemental heat, first evacuate flammable vapors which may accumulate in the tank sump.

Do not enter tank or tank sumps unless following OSHA guidelines for confined space entry. Failure to follow OSHA guidelines could result in death or serious injury.



⚠ WARNING

Always wear protective goggles and gloves when mixing and applying adhesive or layups. The liquid materials are flammable. Keep adhesive and resin away from sparks and ignition sources.

- 4.1. Containment Solutions™ tank sumps must be installed using only our supplied assembly kits.
 - 4.1.1. Adhesive kits (Kit AD E) are used to field bond tank sump components using EZ-Fit adhesive channels.
 - 4.1.2. Layup kits (Kit LK) are used to field bond joints without EZ-Fit adhesive channels.
- 4.2. All assembly kits (Kit AD E or Kit LK) should be stored in a location at 50° - 100°F (10° - 38°C). Use by expiration date shown on the box.

4.3. Temperature Considerations:

- 4.3.1. Cool Weather (less than 50°F):
 - 4.3.1.1. Preheat the resin and hardener to 50-75°F.
 - 4.3.1.2. Before adhesive or layup is applied, add supplemental heat. Apply heat to keep joint surfaces over 50°F.
 - 4.3.1.3. After adhesive or layup is applied, continue to apply supplemental heat until it begins to harden.
- 4.3.2. Warm Weather (between 51°F and 80°F):
 - 4.3.2.1. Adhesive or hand layup will harden in approximately 20 minutes.
 - 4.3.2.2. No supplemental heat required.
- 4.3.3. Hot Weather (above 80°F):
 - 4.3.3.1. Apply adhesive or layup more rapidly (adhesive and resin may harden in less than 15 minutes).
 - 4.3.3.2. To increase working time, cool the adhesive or resin to 50°F to slow down chemical reaction.
- 4.3.4. After mixing adhesive and hardener, you will have no more than 20 minutes to complete the application before the resin begins to harden.
- 4.3.5. Recommended method for supplemental heat is to transfer warm air to the tank sump while keeping ignition sources away.

EZ-FIT ADHESIVE JOINTS (KIT AD E)

4.4. Kit Contents: This kit is designed for Adhesive Joints.

Items	Size	Qty.
Mix Instructions Sheet (INST 6051)		1
SDS for Resin Mix (INST 6070)		1
SDS for Hardener (INST 6071)		1
Putty Knife		1
Resin	1 gal. can	1
Hardener	1 qt. can	1
Grout Bag		1
Mixing Stick		1

- 4.4.1. Read the following instructions completely before applying adhesive to EZ-Fit channel (see Figure 4-1).
- 4.4.2. Dry fit all tank sump components prior to sealing joints, as outlined in Section 3.
- 4.4.3. Each adhesive joint requires (1) adhesive kit.
- 4.4.4. Single-wall tank sump adhesive joints include two (2) EZ-Fit adhesive channels per joint, interior and exterior.
 - 4.4.4.1. 42 in. and 48 in. diameter tank sumps require (1) adhesive kit per channel, totaling two (2) adhesive kits per joint (one outside, one inside).
 - 4.4.4.2. 54 in. diameter tank sumps require one (1) adhesive kit per interior channel and two (2) adhesive kits per exterior channel, totaling (3) adhesive kits per joint.
- 4.4.5. Thoroughly mix two part adhesive by hand or with a power mixer following the mixing instructions contained in the adhesive kit. Pour into grout bag.
- 4.4.6. With the tank sump components in place, fill the adhesive channel completely in one 360 degree pass. (see Figure 4-1).
- 4.4.7. When more than one adhesive kit will be required to fill the joint, fill the joint using two or more operators, each starting at the same place and going opposite directions filling the joint so the epoxy is uncured when they meet.

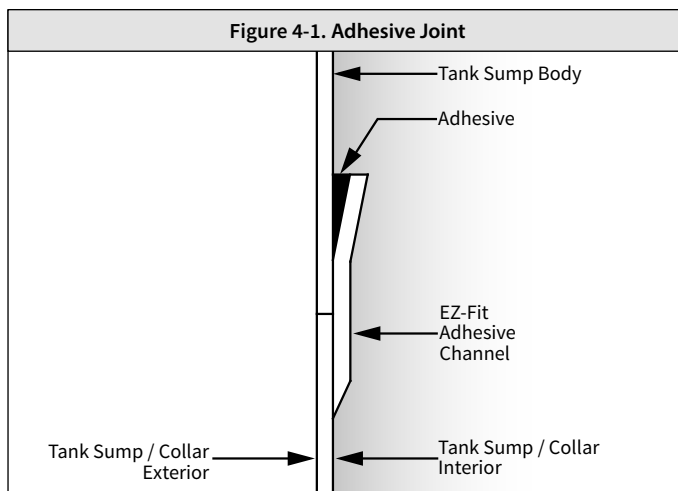

4.4.8. Joint may take up to 24 hours to cure dependent upon the temperature. Allow adhesive to cure before moving the joined parts.

HAND LAYUP JOINTS (KIT LK)

4.5. Kit Contents: This kit is designed for Hand Layup Joints.

Items	Size	Qty.
Pair Rubber Gloves	X-Large	1
Plastic Roller	¾ in. x 3 in.	1
Felt Roller Handle	3 in.	1
Felt Roller Pad	3 in.	2
Chopped Strand Fiberglass Mat	6 in.W x 33 in.L	15
Mixing Stick		1
Mix Instruction Sheet (INST 6032)		1
SDS for Resin (ACC 5015)		1
SDS for Curing Agent (Cadox L-50A-VR)		1
Resin (Part A)	1 gal. can	1
Curing Agent	5 gram tubes	15

- 4.5.1. Read the following instructions completely before applying resin to glass and/or layup joint (see Figure 4-3).
- 4.5.2. Dry fit all tank sump components prior to sealing joints, as outlined in Section 3.
 - 4.5.2.1. Gaps between two joints greater than ½" may be covered with a maximum width 1" wide tape to prevent resin from running into joint (see Figure 4-2).
- 4.5.3. 42 in. and 48 in. diameter tank sumps require (1) layup kit per joint. 54 in. diameter tank sumps require (2) layup kits per joint.
- 4.5.4. Thoroughly mix resin and catalyst following the mixing instructions in the layup kit.
- 4.5.5. Resin coat previously ground mating surfaces with felt roller.
- 4.5.6. Apply 3 layers of glass layup, saturated with resin, 360° around tank sump, centered on joint. All layup joints must overlap a minimum of 1 in. but not exceed 2 in. in circumferential direction (see Figure 4-3).
- 4.5.7. Using the ribbed roller supplied in the kit, hand roll over entire surface of layup, working air bubbles out from under the fiberglass mat.

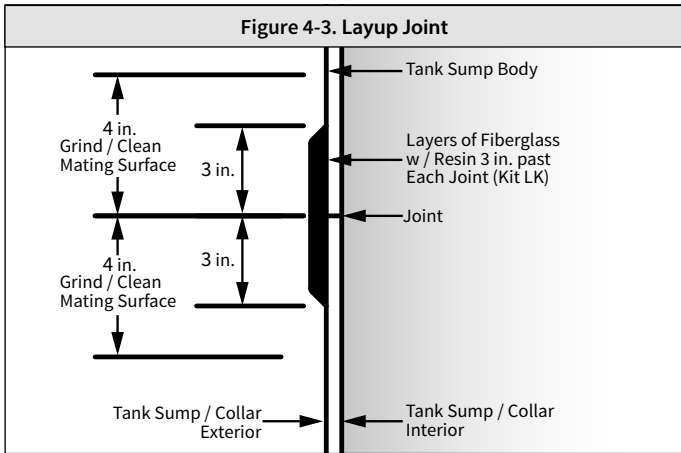
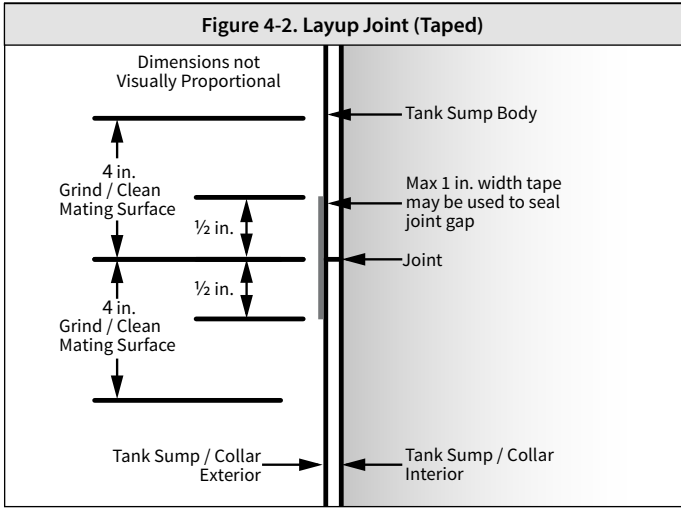

4.5.8. Joint may take up to 24 hours to cure dependent upon the temperature. Allow adhesive to fully cure before moving the joined parts.

5. ASSEMBLED TANK SUMPS

⚠ WARNING

Failure to properly seal and test joints may result in product loss, environmental damage, explosion, or fire.

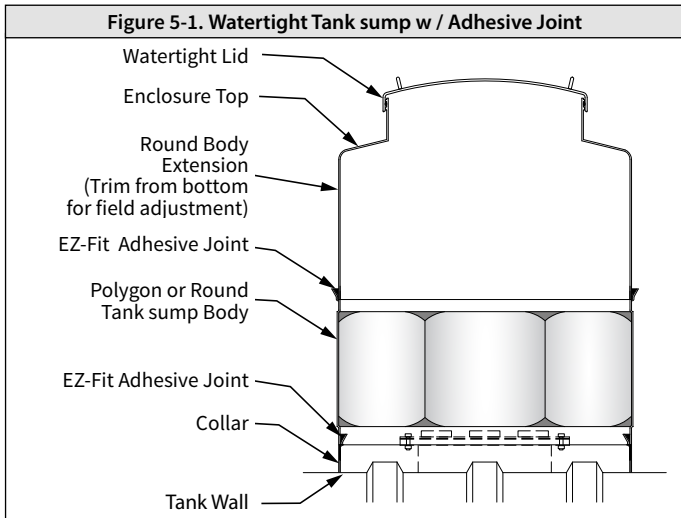

- 5.1. All joints must be sealed with our supplied kits.
- 5.2. Keep the tank sump lid, gasket and gasket groove free from contaminants.
- 5.3. When installing lid, apply additional lubricant to gasket as needed.
- 5.4. Ensure gaskets are installed with the fins angled down, away from the lid as illustrated (see Figure 5-2 and 5-3).
- 5.5. If necessary, step on lid perimeter until properly seated.
- 5.6. NON-WATERTIGHT tank sump (Friction Fit Tank Sump): The tank sump lid will loosely fit tank sump top and will not be watertight and does not include a gasket.

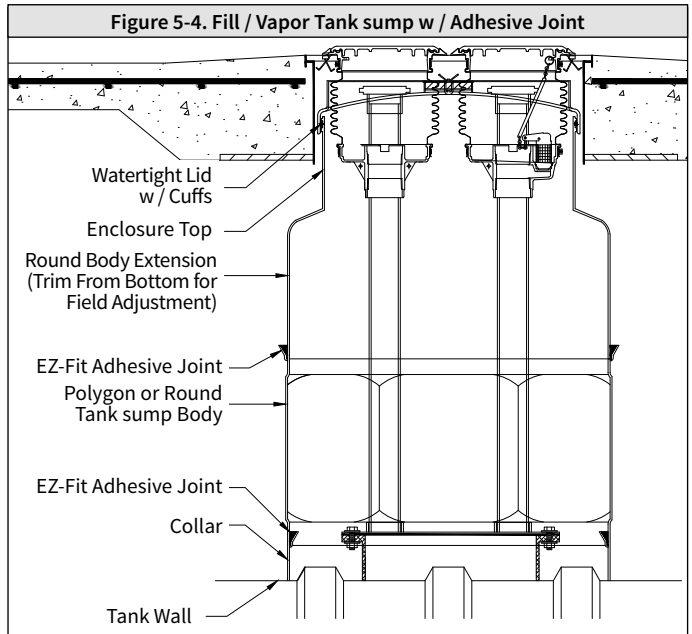
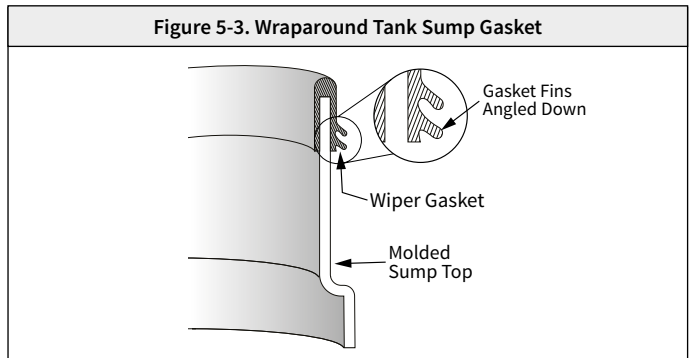
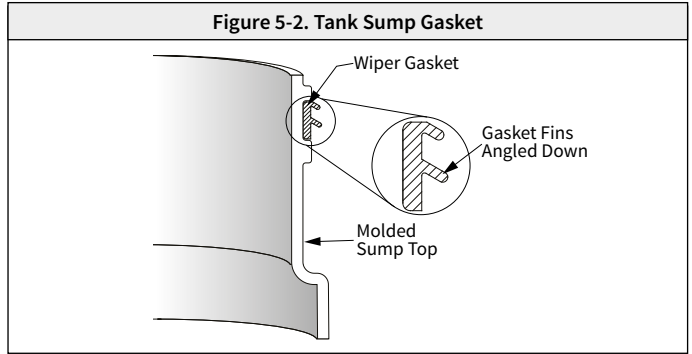

6. POST ASSEMBLY TEST

NOTICE

DO NOT pressure test tank sump. If applying vacuum, DO NOT apply more than 25 inches water vacuum to tank sump enclosure or damage may occur.

- 6.1. Fill tank sump with water at least 4 in. above highest joint or penetration.
- 6.2. Record the liquid level.
- 6.3. Wait a minimum of 1 hour.
- 6.4. Re-measure and record the liquid level. A liquid change of more than $\frac{1}{8}$ in. (0.125 in.) indicates a possible leak (see Figure 6-1).

Figure 6-1

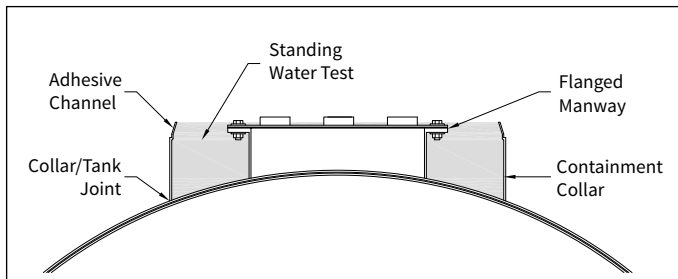

- 6.5. Visually inspect for leaks in the following locations:
 - All penetrations
 - All fittings
 - Secondary containment collar and tank sump joint
 - Secondary containment collar and tank joint
- 6.6. Test liquids must be disposed of properly. Check with the authorities having jurisdiction regarding requirements for proper disposal.
- 6.7. Initial jobsite testing:
 - 6.7.1. The installation contractor must leak test this collar and tank sump before the tank installation is complete.

7. BACKFILL

- 7.1. The use of approved backfill material is critical to long term tank sump performance. Failure to use approved backfill may result in tank sump failure and will void the limited warranty (see Figure 8-1).
- 7.2. Limestone, sandstone, crushed concrete, seashells, or shale CANNOT be used as backfill, because they break down over time.
- 7.3. Replace all excavated native soil with approved backfill of proper size and gradation. Use backfill which meets ASTM C-33 for quality and soundness.
- 7.4. Require your backfill supplier to certify that the backfill meets this specification.
- 7.5. Keep backfill dry and free of ice in freezing conditions.
- 7.6. For alternative backfill for tank sumps, other than what is specified in Figure 8-1, refer to INST 6060.
- 7.7. To help insure proper backfill material size, we offers an Approved Backfill Calculator available on our website.

Figure 8-1

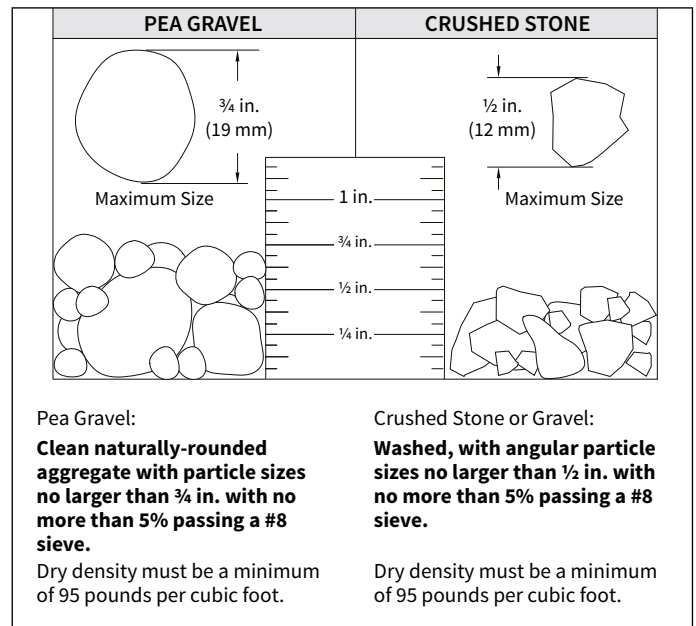

8. SURFACE SLAB & TANK SUMP CLEARANCES

- 8.1. Isolate all tank sumps from direct traffic loading.
- 8.2. After backfilling to top of tank sump:
 - 8.2.1. Backfill around tank sump top to a minimum of 3 in. above the horizontal position of the enclosed top. Place a 5 ft. x 5 ft. x $\frac{3}{4}$ in. rigid board with hole cut out to fit around tank sump on backfill to support concrete and provide a channel for water runoff (see Figure 8-1).

Figure 8-1

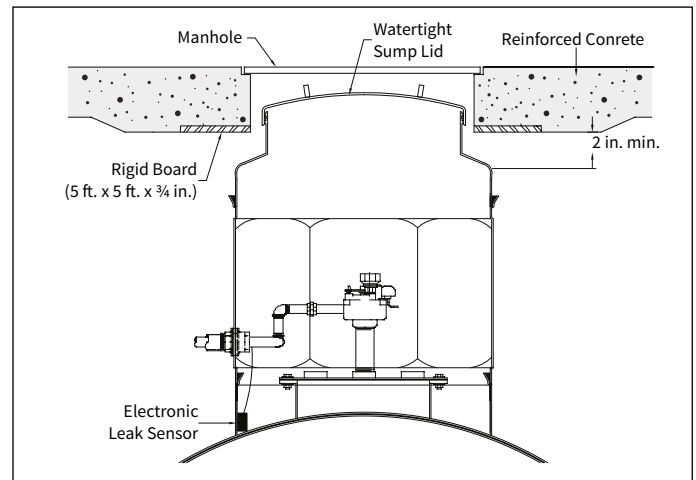

- 8.2.2. Use a grade access manhole large enough to allow tank sump lid removal after installation.
- 8.2.3. Adequate clearances must be maintained between the tank sump lid and manhole cover to prevent the direct transfer of traffic load to the tank sump.
- 8.2.4. Pour slab directly onto rigid board.
- 8.2.5. If the tank sump is located in a traffic area, the concrete traffic pad, reinforcement and thickness must be designed for job conditions and traffic loads to assure concrete traffic pad integrity. It is the responsibility of the tank owner or tank owner's representative to design the traffic pad for all loads.

9. OPERATING GUIDELINES

- 9.1. The tank sump installation checklist, these instructions, and any correspondence related to the tank sump installation must be retained by the tank owner. The checklist will be required and must be provided when making a warranty claim.
- 9.2. For the life of the installation, the installed tank sump must comply with NFPA (30, 30A and 31) and all applicable Federal, State, Local or Provincial codes and regulations.
- 9.3. It is the responsibility of the tank sump owner/operator to follow these instructions and operating guidelines and all limitations as stated in the limited warranties in effect at time of delivery.
- 9.4. The limited warranty in effect at the time of tank sump delivery will apply and is available online.
- 9.5. Tank sump entry is considered a confined space entry.
- 9.6. The tank sump owner should not allow anyone other than properly trained and equipped personnel to enter a tank sump.
 - 9.6.1. Proper permits and industry accepted minimum standards must be followed before anyone can enter a tank sump.
 - 9.6.2. Contact Field Services at (800) 822-1997 if repairs or modifications are required.
- 9.7. Tank sump entry by unqualified personnel can lead to fire, explosion, asphyxiation and/or death. Tank sumps are for use by qualified personnel with proper training and safety equipment.

▲ WARNING

Do not enter tank or tank sumps unless following OSHA guidelines for confined space entry. Failure to follow OSHA guidelines could result in death or serious injury.



ASPHYXIATION



FIRE



EXPLOSION

- 9.8. Do not attempt to repair or modify your tank sump. Any repairs or modifications will void the tank sump limited warranty.
- 9.9. If tank sump entry is required for repairs or modifications or inspections, contact Field Services at (800) 822-1997.
- 9.10. The tank sump must be continuously monitored with an electronic leak detector for potential spills or leaks.
- 9.11. Tank owner/operator must leak test the collar and tank sump after any damage, repairs, modifications, or regulatory requirements.
- 9.12. The gasket is a consumable product which will have to be replaced periodically or when it shows a leak during a tightness test.
 - 9.12.1. Ensure gasket is installed per instructions in Section 5, 5.4 and Figure 5-2.

- 9.13. The gasket lubricant will require periodic replacement as it will degrade over time. Any lubricant that will not dissolve in gasoline or water, nor attack Buna-N rubber is acceptable. While not as long lasting, other lubricants like barium grease, or petroleum jelly can also be used.
- 9.14. Remove the tank sump lid by using one handle along the edge of the lid.

10. TANK SUMP INSTALLATION CHECKLIST

- 10.1. The Installation Checklist in this manual must be properly completed, signed by the tank owner's representative and the installing contractor.
- 10.2. The tank sump installation checklist, these instructions, and any correspondence related to the tank sump installation must be retained by the tank owner. The checklist will be required and must be provided when making a warranty claim.
- 10.3. Single-wall tank sump installation check list is on next page.

Single-Wall Tank Sump Installation Checklist for Containment Solutions Fiberglass Tank sumps

The tank sump installation checklist, these instructions, and any correspondence related to the tank sump installation must be retained by the tank owner. This checklist will be required and must be provided when making a warranty claim.

Site Owner _____ Date of Installation _____

Site Address _____
 Street City State Zip

Installing Contractor _____
 Company Street City State Zip

Single-Wall Tank sump

Initial On Lines Below

Completed

- 1. All tank sump components have been inspected for damage prior to installation. _____
- 2. All tank sump parts and components were handled and stored according to these instructions. _____
- 3. All joints have been prepared per these instructions. (check one below) _____
 - EZ-Fit Adhesive Joints (KIT AD)
 - Hand Layup Joints (KIT LK)
 - Both
- 4. Date on Assembly Kit Box _____ Date kit used _____
- 5. All joints were given a minimum of 5 hours to cure without parts being moved or disturbed. _____
- 6. Tank sump tops are properly protected from traffic load. _____
- 7. Approved backfill was used around and under the entire tank sump. _____
- 8. Gaskets are lubricated, clean, and undamaged. Finned gaskets have fins pointing down. _____
- 9. All tank sump annular spaces were pressure / soap tested for tightness prior to backfilling. _____
- 10. Diameter and quantity of tank sumps installed and tested. _____
 - 42 in. _____qty.
 - 48 in. _____qty.
 - 54 in. _____qty.

Installation was in accordance with most recent Installation Instructions Pub. No. INST 6030.

Owner Representative (Print Name) _____ Date _____

Contractor Representative (Print Name) _____ Date _____

Owner Representative (Signature) _____

Contractor Representative (Signature) _____

THIS PAGE IS INTENTIONALLY LEFT BLANK.

THIS PAGE IS INTENTIONALLY LEFT BLANK.

Fiber Glass Systems

17115 San Pedro Ave., Suite 200
San Antonio, Texas 78232
USA

Conroe Office

500 Conroe Park West Drive
Conroe, Texas 77303
USA

© June 2022 NOV Inc. All rights reserved.
INS1301 | JIRA 16699