

NOTE:
 OVERALL SHIPPING DIMENSION: 17'-4" L X 3'-3" W X 3'-5" H

ITEM	SIZE	SUGGESTED FUNCTION
1	2"	SPARE
2	2"	MECHANICAL GAUGE/ SPARE
3	2"	FILL
4	6"	PRIMARY TANK EMERGENCY VENT
5	2"	PRIMARY TANK WORKING VENT
6	SMALL	LIFTING LUG
7	6"	SECONDARY CONTAINMENT EMERGENCY VENT
8	2"	SECONDARY WORKING VENT

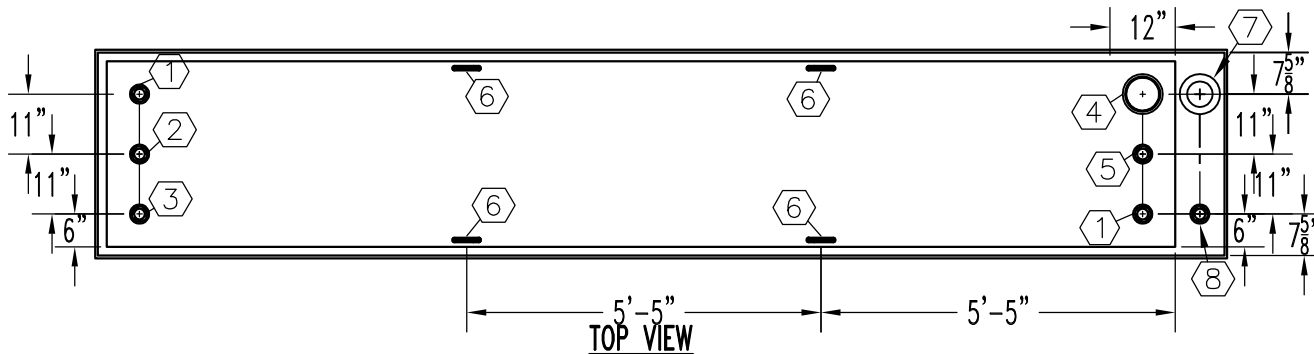

TANK SPECIFICATIONS

VENTING CAPACITY: PRIMARY-168,000 CUBIC FEET PER HOUR
 SECONDARY-190,000 CUBIC FEET PER HOUR

MATERIAL: PRIMARY TANK - 3/16" THK.
 SECONDARY TANK - 10 GA.

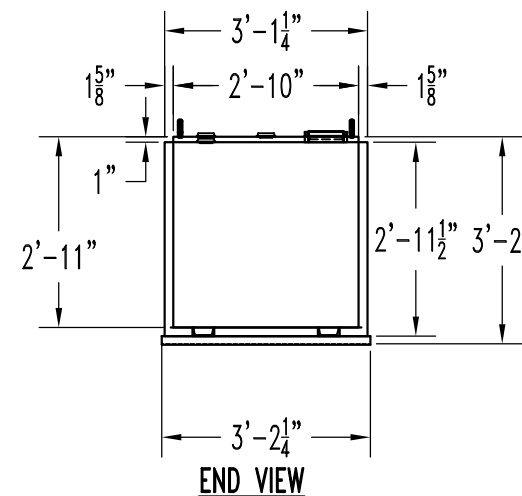
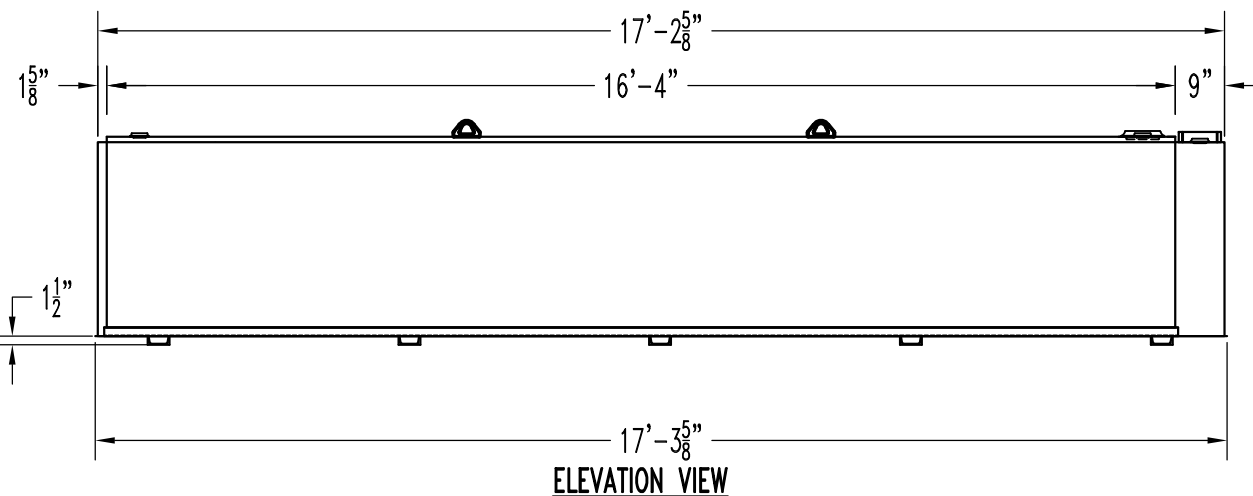

PRODUCT CODE	GALLONS	DESCRIPTION	OVERALL SIZE	SHIP WT.
UCAA101MDS000	1000	UL-142 DOUBLE WALL UNDER CATWALK TANK	17'-4" L X 3'-3" W X 3'-2" H	2,600 LBS.

THIS DRAWING AND DESIGN SHOWN HEREIN IS THE PROPERTY OF CONTAINMENT SOLUTIONS. USE OR COPIES THEREOF CANNOT BE MADE WITHOUT WRITTEN CONSENT.

CUSTOMER NAME: _____
APPROVED BY: _____ DATE: _____

CONTAINMENT SOLUTIONS

DRAWN BY: D. ROVANG	DATE DRAWN: 01-01-14
DWG NUMBER: 5100229	SCALE: 1:36
REV: _____	REV BY: _____
DATE: _____	SHEET: 1 OF 1