

NOTE:

OVERALL SHIPPING DIMENSION: 16'-5" L X 2'-11" W X 3'-4" H

ITEM	SIZE	SUGGESTED FUNCTION
1	2"	SPARE
2	2"	MECHANICAL GAUGE/ SPARE
3	2"	FILL
4	6"	PRIMARY TANK EMERGENCY VENT
5	2"	PRIMARY TANK WORKING VENT
6	2"	PUMP/SPARE
7	SMALL	LIFTING LUG

TANK SPECIFICATIONS

VENTING CAPACITY: 168,000 CUBIC FEET PER HOUR

MATERIAL: PRIMARY TANK - 3/16" THK.

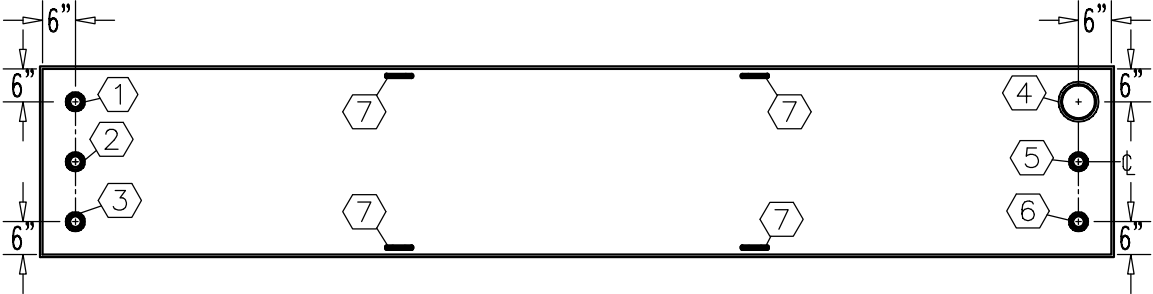

TOP VIEW

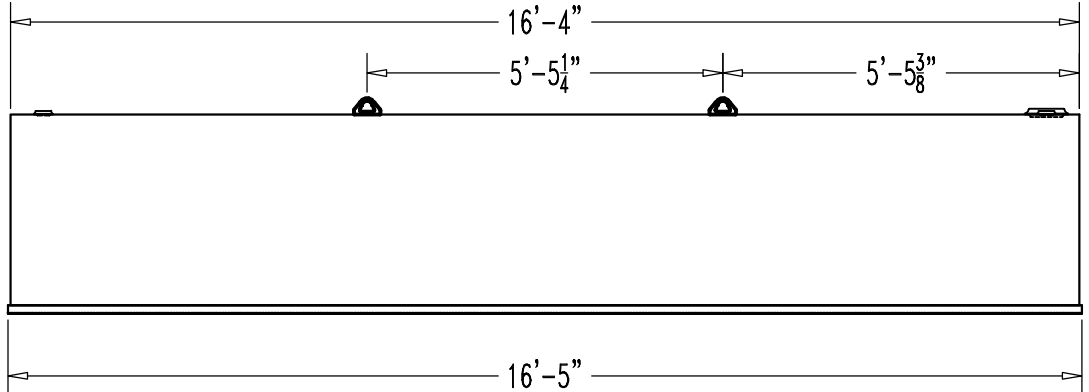

ELEVATION VIEW

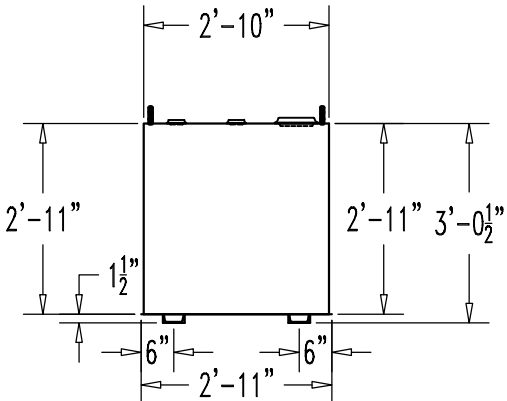

END VIEW

PRODUCT CODE	GALLONS	DESCRIPTION	OVERALL SIZE	SHIP WT.
UCAA101MSS000	1,000	UL-142 SINGLE WALL UNDER CATWALK TANK	16'-5" L X 2'-11" W X 3'-1" H	1,475 LBS.

THIS DRAWING AND DESIGN SHOWN HEREIN IS THE PROPERTY OF CONTAINMENT SOLUTIONS. USE OR COPIES THEREOF CANNOT BE MADE WITHOUT WRITTEN CONSENT.

CUSTOMER NAME: _____

APPROVED BY: _____ DATE: _____



DRAWN BY: D. ROVANG	DATE DRAWN: 01-01-14
DWG NUMBER: 5100227	SCALE: 1:36
REV: _____	REV BY: _____
DATE: _____	SHEET: 1 OF 1