

NOTE:
OVERALL SHIPPING DIMENSION: 4'-9" L X 3'-2" W X 3'-6" H

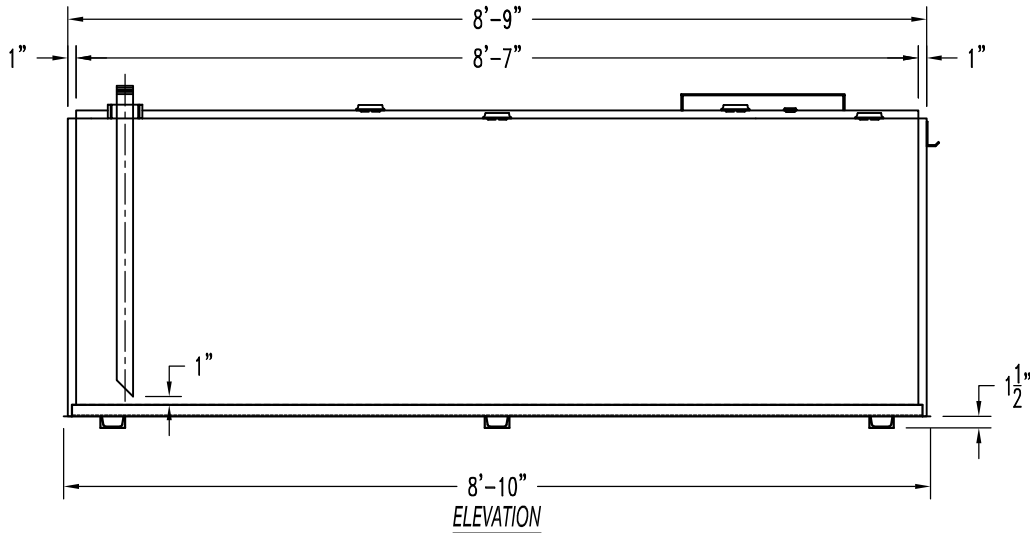
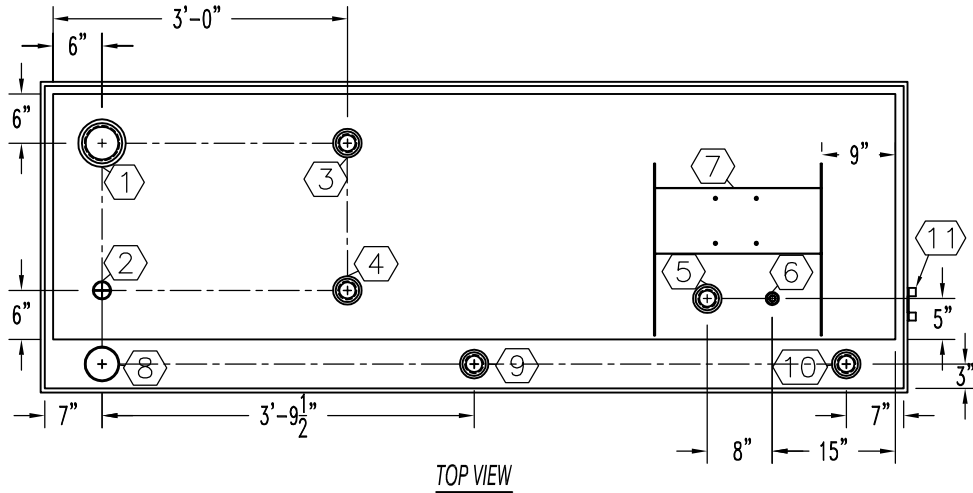

ITEM	SIZE	SUGGESTED FUNCTION
1	4"	PRIMARY TANK EMERGENCY VENT
2	2"	SUCTION PIPE W/KAMLOCK & DUST CAP
3	2"	PRIMARY TANK WORKING VENT
4	2"	MECHANICAL GAUGE/SPARE
5	2"	AIR OPERATED HIGH LEVEL SHUTOFF VALVE
6	3/4"	PRODUCT DISCHARGE
7		DIAPHRAGM PUMP BRACKET,"PBB004"
8	4"	SECONDARY CONTAINMENT EMERGENCY VENT
9	2"	SECONDARY MONITOR PORT/ SPARE
10	2"	SECONDARY WORKING VENT
11		HOSE BRACKET

TANK SPECIFICATIONS

VENTING CAPACITY: PRIMARY TANK - 94,800 CUBIC FEET PER HOUR
 SECONDARY TANK - 105,000 CUBIC FEET PER HOUR
 MATERIAL: PRIMARY TANK - 10 GA.
 SECONDARY TANK - 10 GA.

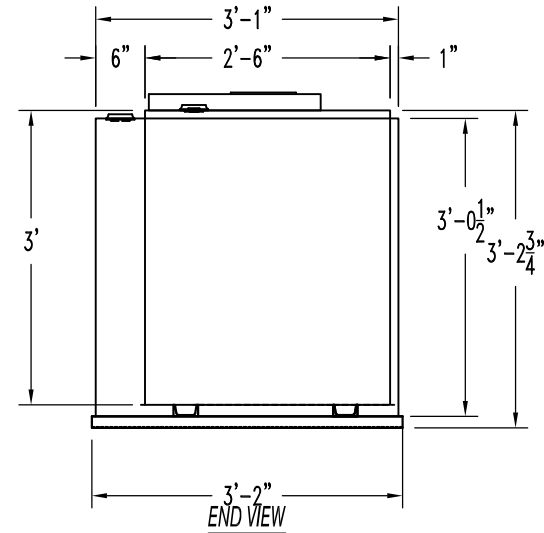

PRODUCT CODE	GALLONS	DESCRIPTION	OVERALL SIZE	SHIP WT.
WEAA1480DS000	480	UL-142 DOUBLE WALL WASTE EVAC. TANK	8'-10" L X 3'-2" W X 3'-3" H	1,300 LBS.



THIS DRAWING AND DESIGN SHOWN HEREIN IS THE PROPERTY OF CONTAINMENT SOLUTIONS. USE OR COPIES THEREOF CANNOT BE MADE WITHOUT WRITTEN CONSENT.

CUSTOMER NAME: _____
APPROVED BY: _____ DATE: _____

DRAWN BY: D. ROVANG		DATE DRAWN: 01-01-14	
DWG NUMBER: 5100208		SCALE: 1:24	
REV:	REV BY:	DATE:	SHEET: 1 OF 1